



EIFS Inspection Report

For the Property Located At:

████████████████████
Virginia Beach, VA 23453

Report Prepared For:

████████████████████



TABLE OF CONTENTS

1. Introduction

- 1.1 Purpose of this inspection
- 1.2 Scope of this inspection
- 1.3 Limitations of Liability
- 1.4 Further Testing
- 1.5 Repair Follow-up and Annual Inspections

2. Your Moisture Inspection

- North, South, East and West Elevation Grid-Style Photos with potential problem areas marked
- Summary

3. Typical Moisture Problems in Stucco Homes & Remedial Methods

- 3.1 Moisture Problems Related to Unsealed EIFS/Stucco Penetrations
- 3.2 Moisture Problems Related to Doors & Windows
- 3.3 Moisture Problems Related to Improper EIFS/Stucco Termination at Grade
- 3.4 Moisture Problems Related to Improper Kickout and Other Roof Flashings
- 3.5 Moisture Problems Related to Improper Deck, Balcony & Patio Terminations
- 3.6 Moisture Problems Related to Cracks and Breaches in the Stucco
- 3.7 Moisture Problems Related to EIFS/Stucco Accents and Flat Stucco Surfaces
- 3.8 Moisture Problems Related to Chimneys
- 3.9 Moisture Problems Related to Gutters and Downspouts
- 3.10 Moisture Problems Related to Improper Transitions (Brick to EIFS/Stucco etc.)

4. Stucco Information, Care and Maintenance

- 4.1 Types of Stucco
 - Exterior Insulation Finish Systems (EIFS)
 - Traditional Hard Coat Stucco Systems
 - Water Management or Drainable EIFS Systems
- 4.2 Is EIFS/Stucco a Good Cladding System?
- 4.3 Care and Maintenance

5. Information About Our Company

I. INTRODUCTION

1.1 PURPOSE: Enclosed is your EIFS/Stucco Moisture Inspection. The purpose of this moisture inspection is to help assess the condition of the stucco system by looking for visible installation flaws, inadequate water diversion and sealant failures and conduct random moisture readings using electronic moisture scan devices. Please note that the provision of a scope of work for remedial repairs is not the purpose of this inspection. *Further investigation may be needed to determine the extent of water damage, if any, and how best to modify your home to address any moisture problems that may be indicated by this inspection.*

1.2 SCOPE OF INSPECTION: This is a basic, stucco inspection limited to the following:

1. A visual examination of the condition of the EIFS/Stucco exterior sealants, flashing, windows, doors, roof-to-stucco transitions, parapets, gutters, deck-to-building connections, EIFS/Stucco terminations and any penetrations through the EIFS/Stucco
2. Conducting of *random* electronic moisture scanning of the building envelope.
3. Preparing a report of our observations of potential problem areas and recording any high readings found.
4. Providing detailed information on typical moisture-related problems in EIFS/Stucco homes to assist you in maintaining the value of your home.

1.3 LIMITATIONS OF LIABILITY: Because this is a limited inspection, we can make no guarantee, express or implied, that our observations and random moisture readings offer conclusive evidence that no installation or moisture problems exist, or that problems found are all-inclusive. This inspection company, its employees and any divisions shall not be liable for non-visual defects, unseen defects, unspecified defects or hidden damage and conditions existing on the subject property and hereby disclaims any liability or responsibility thereof. All parties concerned agree to hold harmless and indemnify this inspection company involving any liabilities that may result.

1.4 FURTHER TESTING / INVESTIGATION: Our policy is to rely on moisture meter readings as an indicator of relative moisture values between different test spots, not as an absolute value of water content in the substrate. It is difficult to determine if the structural wood of your home has been damaged in areas of high readings without 'probing' and/or removing a core sample of the EIFS/Stucco to allow for visual inspection. Should we feel that further investigation is needed this will be indicated in the summary section of the report.

1.5 REPAIR FOLLOW-UP AND ANNUAL INSPECTIONS: A repair follow-up inspection should be conducted within three months after completion of the repairs to assess the effectiveness of the moisture modifications. This is extremely important. Annual inspections should also be scheduled to ensure that your EIFS/Stucco system remains dry. This way any sealant failures, EIFS/Stucco cracks, etc. can be caught and repaired promptly. Testing and maintaining your home on a regular basis is the best way to prevent costly repairs associated with moisture damage. Also, should you decide to sell your home, annual inspections and maintenance documentation will be a valuable selling tool, providing evidence to show that your home has been inspected and maintained on a regular basis by a reputable and qualified firm.

Project Information

OWNER INFORMATION		BUYER INFORMATION	
Owners	██████████	Buyers	
Property Address	██████████	Buyers Address	
City, State, ZIP	Virginia Beach, VA 23453	City, State, ZIP	
Phone	██████████	Phone	
Owner's Email	██████████	Buyer's Email	
Owners Realtor		Buyers Realtor	
Realty Company		Realty Company	
Phone		Phone	
FAX		FAX	
Realtor's Email		Realtor's Email	
PROPERTY INFORMATION		INSPECTION INFORMATION	
Type of Exterior	EIFS	Date of Inspection	06/13/2020
Substrate (if known)	Unknown	Inspector	EMS
Age of Property	15+	Present at Inspection	Buyer/Owner/Realtor
Square Footage	1,000+	Temperature/Humidity	80
Stories	2	Weather Conditions	Inclement weather pending
Type of Windows	Vinyl Clad Windows	Last Rain	Within last few days

Inspection Test Equipment					
	Test Equipment Description	Test Range			Setting
		Low	Medium	High	
A	Tramex Interior Moisture Encounter (Not Used)	10-14	15-19	> 19	2
B	Tramex Exterior Wet Wall Detector	05 - 10	11-30	31-100	4.5
C	Delmorst Moisture Probe Meter (Not Used)	10-14	15-19	> 19	1
D	Structural Resistance Tester (SRT) (Not Used)	>44 = Pass	<44 = Fail	Higher is better	

NOTE: The test equipment is used to help locate problem areas. It must be understood that the test equipment is not an exact science but rather good tools used as indicators of possible problems. At times, because of hidden construction within the wall cavity, the meters get false readings or no readings at all. Some meters will pick up on metals, wiring, unique wall finishes, etc. Positive readings do not always mean there is a problem, nor do negative readings necessarily mean there is not a problem. We do not use the equipment to obtain exact moisture content, but rather to obtain relative readings between suspected problem areas and non problem areas. This information is then used to help determine potential problem areas which may warrant more investigation. At the time of this inspection there were no elevated moisture readings anywhere.

General Observations

Item Description	Yes	No	Improper	Comments
Sealants at window perimeters	X			Most sealed, see elevation photos for exceptions
Mitre joints (bottom corners) of windows	X			Suggest sealing the inside bottom corners of windows
Alarm sensor penetrations at windows		X		Not observed
Fixed window units and mullion joints	X			
Head flashing at top of windows	X			
Sealants around door perimeter	X			Some not sealed--insure all door perimeters are installed
Sealants at door threshold details	X			Suggest sealing thresholds to casing where not present
Penetrations thru door threshold / tracks	X			Seal all penetrations through threshold/tracks ex: screws
Head flashing at top of doors	X			Common for this area.
Penetrations through EIFS/stucco sealed	X			All penetrations through EIFS should be properly sealed
General appearance	X			Rough general appearance
Cracking evident	X			Some cracking evident
Expansion joints / Control joints	X			No visible expansion joint at 2nd floor line
Exposed mesh	X			Few areas noted where mesh is visible through finish
Impact damage	X			Several areas of impact damage on decorative bands
Rusting aggregates	X			Several rusting aggregates noted
Flat horizontal surfaces	X			Bands have flat surfaces--suggest coating all with elastomeric
Delamination / Fasteners	X			No obvious visible evidence
Terminations and Vinyl accessories	X			
Transition joints (stucco to brick, etc.)		X		
Termination below grade (ground level)		X		
Termination below or at slab levels		X		
Deck flashing				
Flashing at columns				
Kick-out flashing				
Roof soffit terminations into EIFS/stucco				
Eave drip edge flashing				
Sprinkler System				
Gutters				

Front Elevation

Photo5.1

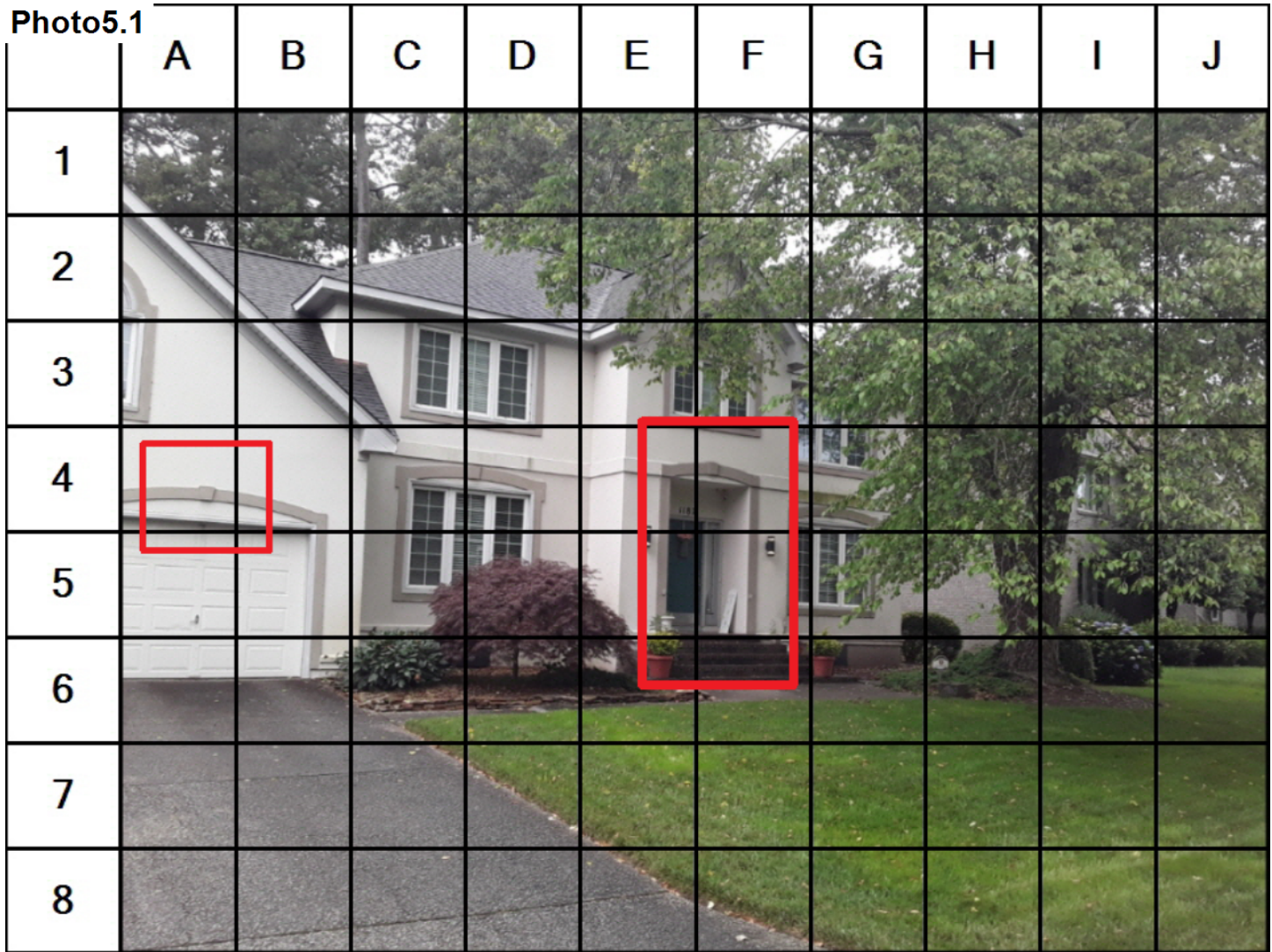

Item	Item Description	Applies to Entire Bldg	Observations / Comment
	Cracks	Yes	Exposed cracks need to be repaired
5E-5F, 4E-4F	Damage	Yes	Damaged stucco needs to be repaired.
	Windows	No	Most windows are sealed but some need to be sealed at the frames and construction (tracks, joints) need to be caulked.
Thru-out	Finishes	Yes	The finish coat needs cleaning and repainting

Detail Photos for Page 7

Photo6.1



Compression Crack
Light Fixture needs to be sealed

Photo6.2



Hole behind the camera needs to be repaired.

Photo6.3



Impact damage and exposed mesh

Photo6.4



Compression Crack

Photo6.5



Impact damage at front corner of
water table band

Photo6.6



Impact damage at water-table band

Detail Photos for Page 9

Photo7.1

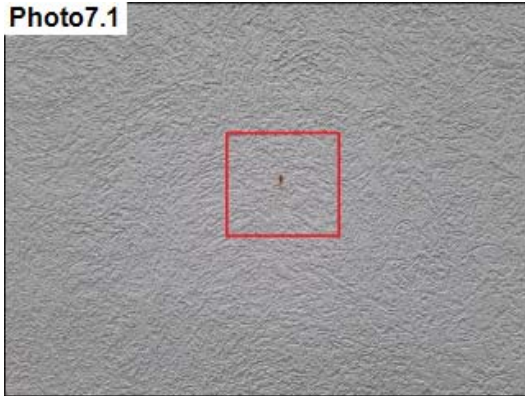

Aggregate rust stains thru-out

Photo7.2



Needs sealant

Photo7.3



Hole in the band

Photo7.4



Mildew & stains from roof

Photo7.5



Foundation paint peeling off

Photo7.6



Previous inspection holes not sealed

Detail Photos for Page 11

Photo8.1

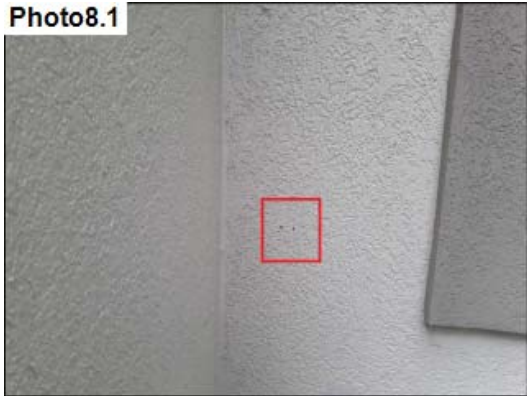

Probe holes not sealed

Photo8.2



Impact damage thru-out

Photo8.3



Impact damage and vegetation on lamina

Photo8.4

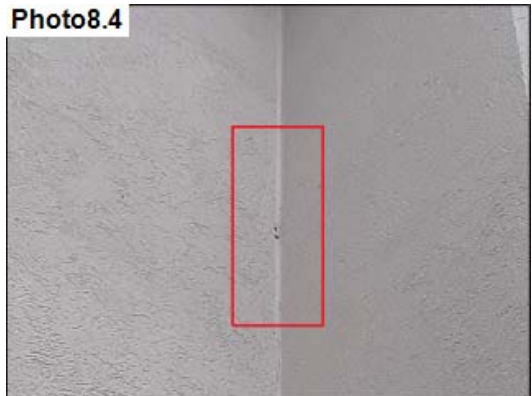

Sealant failure at chimney

Photo8.5

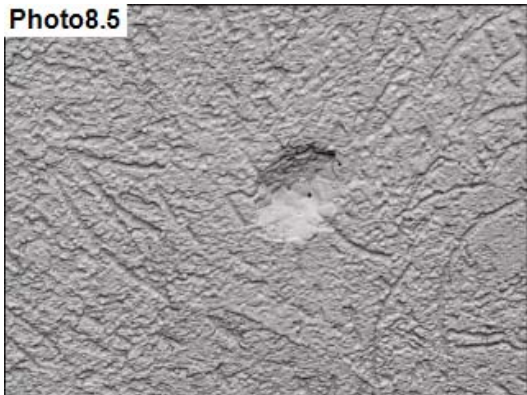

Typical impact damage thru-out

Photo8.6

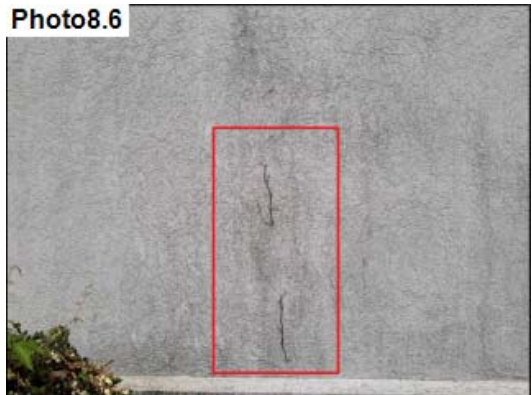

Vegetation/Ivy on lamina

Detail Photos for Page 13

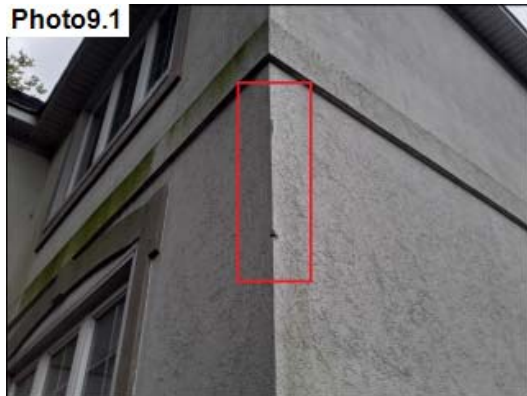

Impact damage at front right corner



Some windows need resealing



Repair needed where railings were removed



Repair needed where railings were removed

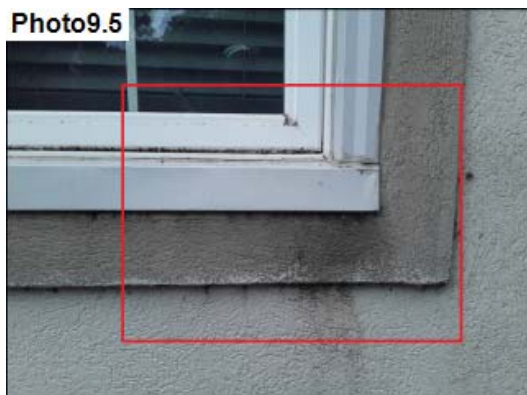

Sealant needed at most windows



Impact damage and compression crack

3.1 Water Intrusion Problems Related to Unsealed EIFS/Stucco Penetrations

Any penetration through the EIFS/Stucco that is left unsealed will allow entry of moisture. Even an average size home can have an extreme number of penetrations, including:

1. electrical boxes
2. exterior receptacles
3. light fixtures
4. plumbing lines and faucets
5. cable TV lines
6. satellite dish mounts
7. security systems
8. gutter straps
9. shutter brackets
10. deck rail penetrations
11. gas lines
12. dryer vents
13. telephone lines
14. damaged or punctured areas of stucco

All penetrations must be sealed with a compatible sealant as recommended by the EIFS/Stucco system manufacturer and required by Model Codes. Damaged areas of stucco must be properly repaired to prevent water intrusion.



Fig. 1 Unsealed penetration



Fig. 2 Sealed pipe penetration



Fig. 3: Sealed gutter-strap and receptacle



Fig. 4 Deck Penetration Sealed

3.2 Water Intrusion Problems Related to Doors and Windows

Doors and windows are one of the most common leak areas in EIFS/Stucco buildings. Leaks can occur in these areas for a variety of reasons, including:

No caulking around perimeter of window or doorframes and thresholds. EIFS/Stucco applicators are supposed to leave a 1/2" gap between the EIFS/Stucco and the frame to allow for a proper joint consisting of backer rod and manufacturer's recommended sealant. If no sealant is installed, a crack will eventually result, due to expansion and contraction, through which moisture or water can enter behind the EIFS/Stucco system. If the EIFS/Stucco installer did not leave the required 1/2" joint, the situation will have to be reviewed to determine the best repair method. Some possible post construction details are shown in the following pages.

Improper or failed joints. Some common reasons for joint failure include improper cleaning or joint preparation, lack of backer rod when needed to control joint depth, improper joint width (should be at least 1/2"), use of inappropriate sealant, or failure to tool the joints. Tooling the joint to a concave surface presses the caulk up against the joint sides to help ensure good adhesion and provides a consistent and neat appearance (Figure 3). Even if joints are properly installed, the life of the sealant is 5 to 20 years depending on the type and quality of sealant used. Sealants should be inspected annually and repairs made promptly.



Fig. 1: Damage caused by No sealants



Fig. 2: Example of unsealed window perimeter



Fig. 4: Damage caused by Alarm sensor



Fig. 3: Serious damage caused by no sealants



3.2 Water Intrusion Problems Related to Doors and Windows (cont'd)

Inadequate or missing flashing. Many windows/doors are installed without the head or sill flashing which is required for EIFS installations by many manufacturers and by Model codes for protection of veneered wall openings). If the leakage cannot be corrected with caulking, corrective repairs may be required to properly install flashing. There are also post construction systems on the market that sometimes can be installed without requiring measures such as removal of the EIFS at the perimeter of the window/door or the removal of the units themselves for repairs/replacement.

Improper house wrap application around windows and doors. If house wrap is not properly lapped and wrapped in the correct sequence around window and door penetrations, any water that intrudes through these areas will be funneled behind the house wrap and saturate the wall cavity causing damage.

Obstructed weep holes. Many windows have tracks with weep holes that are designed to catch any incidental water and weep the water to the outside of the window frame. However, situations are sometimes encountered where the stucco applicator has brought the stucco up past the weep holes causing the water to “dam” up and eventually leak into the walls. These weep holes must be kept clear of EIFS/Stucco caulk, etc. to allow them to fully and freely function.

Punctured window tracks or frames from security system installation. This may also void your window warranty. Sealing these penetrations will many times correct the leakage.

Many window and door units themselves leak through gaps in the door or window frame, sills, tracks and/or at the center mullion where two double hung windows join. This can sometimes be corrected by wet glazing (sealing the frame to glass) or by caulking the gaps in the frames or by making minor modifications to the window. If these measures are not effective, the windows or doors will have to be repaired or replaced with a higher quality window.

Doors: In areas that are prone to strong, gusting winds, in-swing doors seem to be more prone to leakage. Door thresholds should be raised a minimum of two inches and should be sealed to prevent water intrusion. Second floor doors should incorporate "pan flashing" to prevent leakage and potential damage to the areas below. Weather stripping can be used to help ensure water tightness.



Fig.4 Door casing and threshold sealed



Fig. 5 Unsealed security sensor

3.2 Typical Window Detail (cont'd)

Inset Window or Door Detail

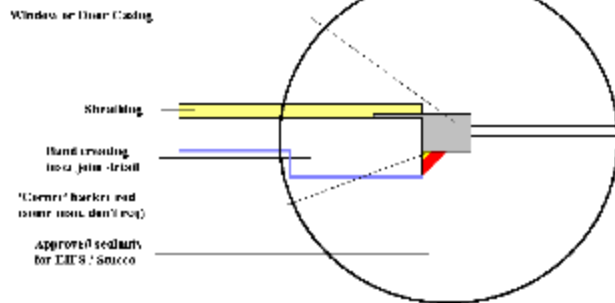

Figure 1: Typical inset window detail (sealed)

Outset Window or Door Detail

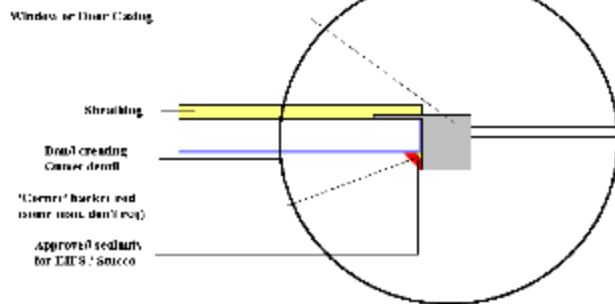

Figure 2: Typical outset window detail (sealed)

Flush Window or Door Detail

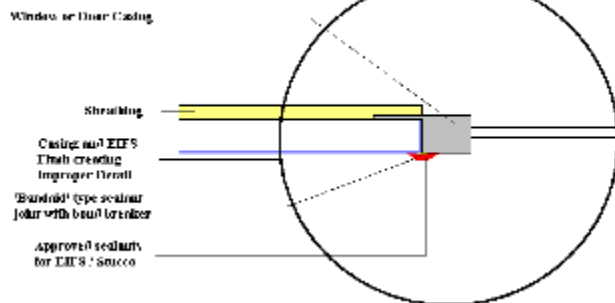

Fig. 3: Sealed 'flush' window detail (band-aid joint)

Proper Window and Door Detail

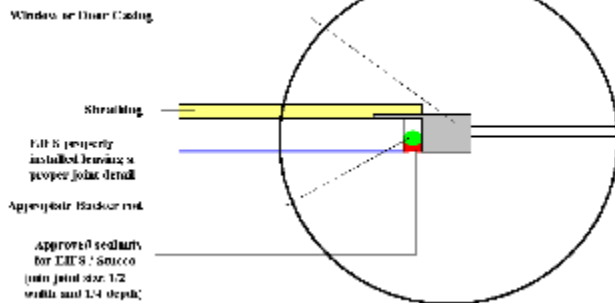

Fig. 4: Window sealed using barker rod at bottom

3.3 Water Intrusion Problems Related to EIFS/Stucco Termination at Grade Level

According to the Model Codes, as well as many state and county codes, all synthetic stucco homes with foam board insulation must be terminated eight inches above the ground. The reasons for this requirement are:

1) To prevent wicking, a process in which standing water is absorbed by the EPS foam board, which leads to mold and mildew behind EIFS. Figure 1 shows an example of a home where the stucco system was not backwrapped and extended below grade. Water wicked up behind the EIFS/Stucco causing mold, mildew and decay of the underlying sheathing. Wicking can also occur when EIFS/Stucco is terminated at grade level as seen in Figure 4.

2) To eliminate a direct path for termites through the EPS board as well as establish easy access for termite inspectors.

Termite problems associated with EIFS/Stucco systems that extended below grade were recognized in 1996 and various code bodies began to change code requirements. Because of the increased risk of termite infestation, many pest control companies won't issue termite warranties for buildings with below grade stucco terminations including 'hard coat' stucco systems in many cases. One way this problem can be resolved by cutting the stucco eight inches above grade and adding a PVC accessory trim to "lock" the EPS board in place (Figure 2). The PVC accessory trim is an optional item that looks nice and eliminates the need for backwrapping the EIFS. The trim is then sealed with a high-quality sealant. Finally, a textured coat is applied to the bare foundation wall and colored to match the existing EIFS. The pictures below show a cutback with accessory trim. Once landscaping is in place, the modification is hardly noticeable (Figure 3).



Fig. 2 Cutback finished using PVC trim



Fig. 1 Moisture caused by the wicking process



Fig. 3 Cutback complete with landscaping



Fig. 4 Moisture at improper termination

3.4 Water Intrusion Problems Related to Improper Kickout and Other Roof Flashing

Kickout Flashing: Many water intrusion problems in stucco or EIFS homes are the result of improper kickout flashing installation or the lack of kickout flashing. Kickout flashing should be installed where a roof line terminates or intersects with a vertical wall. The word kickout means exactly that; it kicks the water out and away from the EIFS/Stucco system.

If no kickout is installed (Figure 1) or if it is improperly installed/sealed (Figure 2), the water can run down the edge of the roof next to the EIFS/Stucco wall and enter behind the EIFS/Stucco at the point where the roof terminates into the EIFS/Stucco. This will allow substantial moisture accumulation that will eventually cause decay as seen in Figure 3.

Properly installed kickout flashing is absolutely essential. An example of a proper installation can be seen in Figure 4.

Installation of a kickout flashing in an existing stucco system involves cutting out the stucco to reveal the step flashing, inserting the kickout flashing under and behind the step flashing. New EIFS/Stucco base, mesh and finish coat is then applied to blend in with the adjacent EIFS/Stucco as closely as possible. Application of bond breaker and sealant is then required as shown in Figure 5. If stucco color cannot be closely matched, it may be necessary to coat the area to a corner if possible.

Other Roof Flashing: Since many EIFS/Stucco homes have complex roofing designs, other critical flashing areas may also be improperly detailed. Any roofline that terminates into EIFS/Stucco may pose a problem.



Figure 1: No kickout flashing



Fig 2: Improper installation (unsealed)



Figure 3: Failed flashing



Fig 4: Proper repair kickout installation

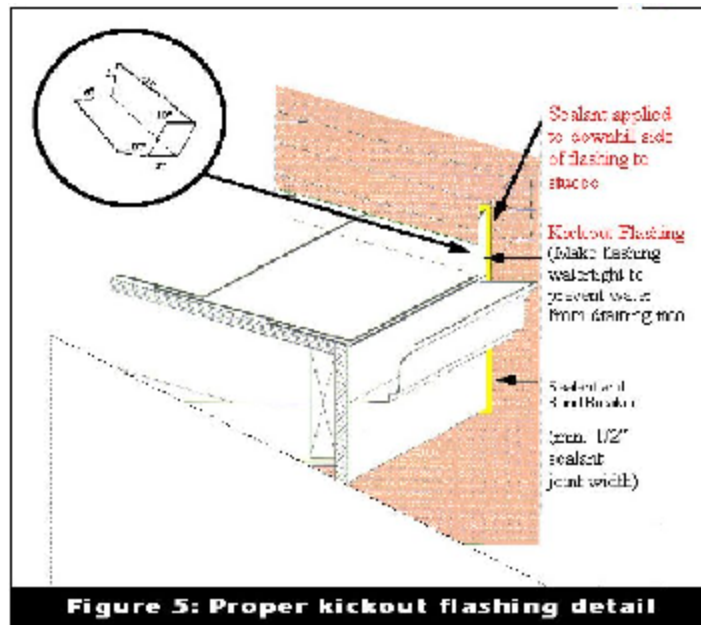
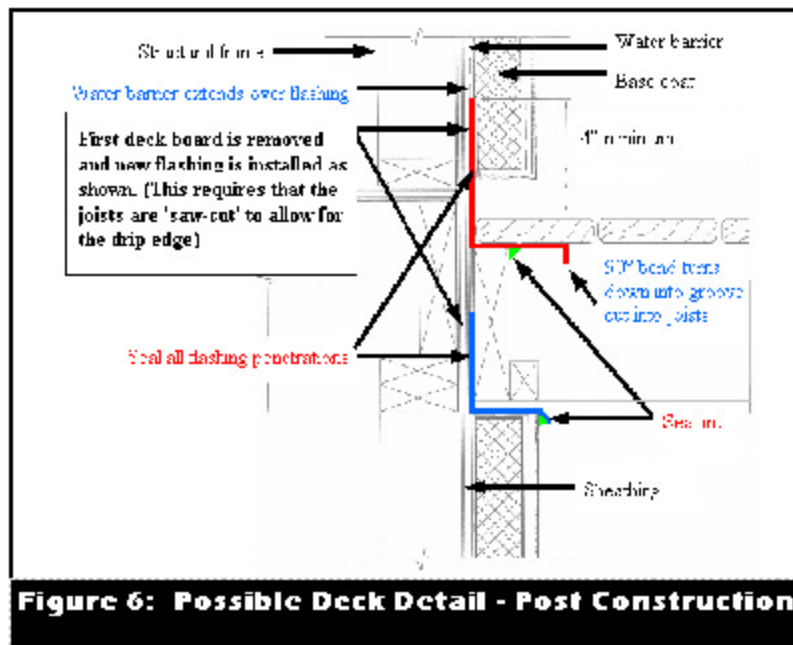
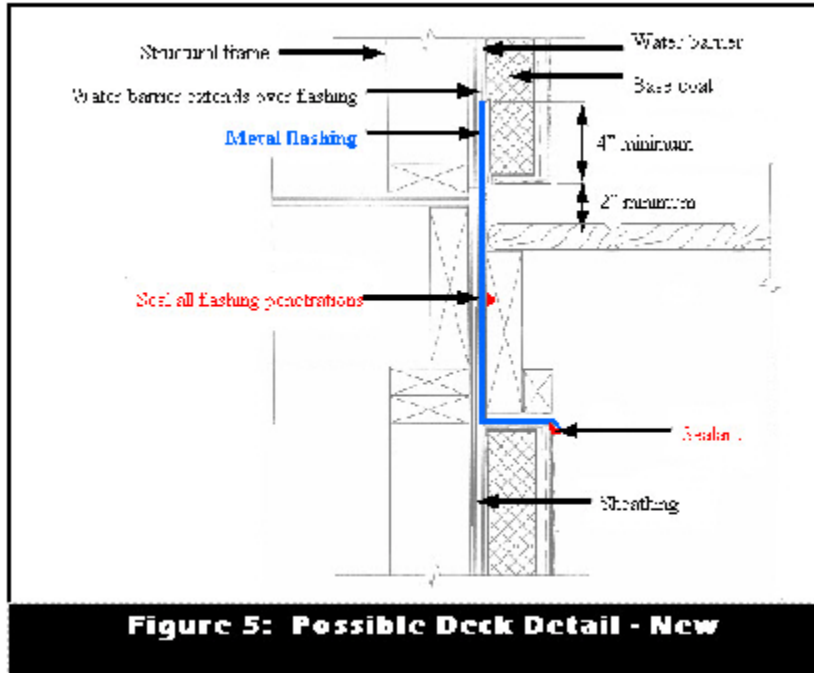

Figure 5: Proper kickout flashing detail

3.5 Water Intrusion Problems Related to Improper Deck and Balcony Terminations (Cont'd)



3.6 Water Intrusion Problems Related to Cracks and Breaches in the EIFS/Stucco

It does not take a very big crack to allow water intrusion. In fact, a crack as small as 1/16" of an inch wide can permit water to enter behind the EIFS/Stucco especially with a EIFS/Stucco system that has no moisture barrier. All cracks 1/16" wide or larger and all damaged areas of EIFS/Stucco should be properly repaired as per manufacturers guidelines. Many times the patched areas will still be slightly noticeable even with a good repair application. Extreme cracking will sometimes require the reapplication of EIFS base, mesh, and finish to prevent more cracking and provide a consistent appearance. Cracking is common in hard coat stucco systems, therefore expansion joints are called for every 144 sf, as well as between floorlines and extending vertically from window and door corners to help control cracking. One reason EIFS is so popular, is that these expansion joints, which many feel are unsightly, are not usually necessary with EIFS. The exception to this is that they are needed between floorlines to compensate for the cross-grain shrinkage of wood. As seen in Figure 1, the lack of an expansion joint between floorlines will result in a compression crack in this area. Again, consult with manufacturer for specific requirements of expansion joints.

The most common areas that experience cracking in EIFS are at the corners of windows or roof terminations as seen in Figures 2 and 3. To prevent cracking in this area, most manufacturer and EIMA details specify that an additional layer of reinforcement mesh be applied diagonally at the corners of all windows, doors and other openings. This is called "butterfly" mesh.

Another common cause for cracking in EIFS is the failure of the EIFS/Stucco applicator to stagger the insulation boards or filling gaps in the EPS boards with basecoat rather than "slivers" of foam as required by manufacturers.

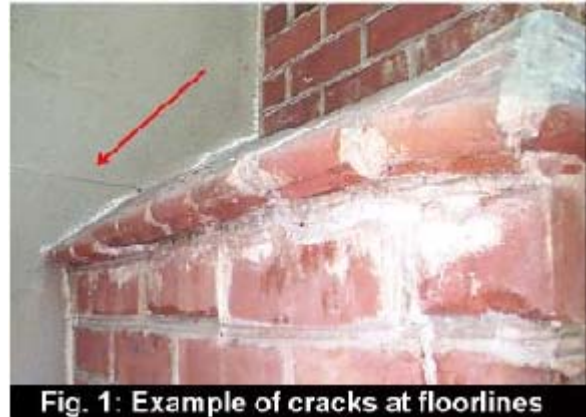

Fig. 1: Example of cracks at floorlines



Fig. 2: Example of crack at window corner

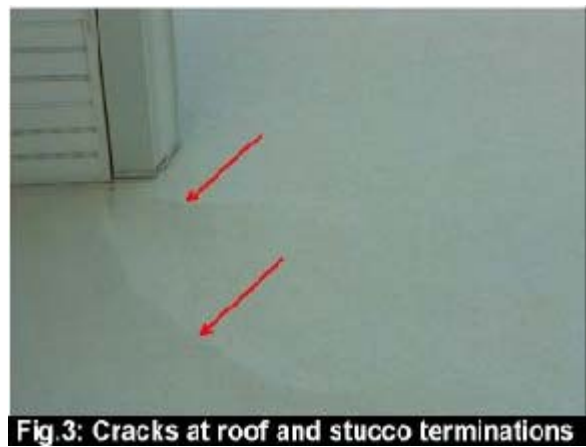

Fig. 3: Cracks at roof and stucco terminations

3.7 Water Intrusion Problems Related to EIFS/Stucco Accents and Flat EIFS/Stucco Surfaces

Flat stucco surfaces, whether conventional hard coat stucco or EIFS, collect and hold water in its rough texture, softening the finish coat, damaging the system and promoting leaks, mildew and discoloration. A good EIFS design will call for bands, quoins, and other accents to have a slope to prevent water accumulation.

The easiest corrective measure would be to coat all flat surfaces with an elastomeric waterproofing coating tinted to match the existing EIFS/Stucco color as closely as possible. Large flat areas, such as a parapet wall, can be capped with metal and sealed.

The joint area where quoins, bands and accents meet the vertical wall surface should be checked for cracks and separation. Cracks and gaps are most likely to occur in this area if these accents have not been properly backwrapped. Backwrapping is bringing the mesh and basecoat around the back of the EPS foam accent. Cracks and gaps should be sealed with an appropriate sealant.



Fig. 1: Flat surfaces at tops of quoins



Fig. 2: Flat surfaces on top of beams



Fig. 3: Flat surfaces collect water

3.8 Water Intrusion Problems Related to EIFS/Stucco Chimneys

No matter whether the exterior cladding is brick, EIFS/Stucco or vinyl siding, chimneys are a prime area for water intrusion since 1) they intersect with the roof and 2) they're subjected to extreme expansion and contraction due to the hot and cold temperature fluctuations when the chimney is used during the winter. This extreme expansion and contraction can fatigue the sealant joints around the chimney and cause cracks or gaps to form around the edge of the stucco where the EIFS/Stucco terminates into the chimney structure, allowing water to enter. Therefore, water diversion through the use of flashing and properly sealed chimney caps are very important.



Fig.1: Example of improperly flashed chimney

A properly designed chimney cap (coping) will shed water away from the stucco to metal joint (Figure 2) and help prevent leaks in this area. The flue should be properly sealed to the "storm flashing" and the chimney cap (coping) sealed to the EIFS/Stucco



Fig.2: Chimney cap to stucco should be sealed

Figure 1 shows a chimney that was not properly flashed (sidewall and kickout flashing see section 3.4) which resulted in wood rot and termite infestation. Figure 2 shows a chimney coping that was not sealed to the EIFS/Stucco which has now separated and will allow water into the chimney chase.

3.10 Water Intrusion Problems Related to Improper Transitions

Many buildings incorporate two or more exterior finishes in their design, such as EIFS/Stucco and brick, EIFS/Stucco and stone, EIFS/Stucco and tile, EIFS/Stucco and wood, EIFS/Stucco and vinyl or aluminum siding, etc.

Different materials expand and contract at different rates. This expansion and contraction causes a crack or gap to form where the two materials join.

If left unsealed, or if sealed improperly, this area will allow water to enter the wall cavity. Examples of this would include EIFS/Stucco to wood trim, stucco to brick (Figure 1), stucco to stone (see Figure 2), stucco to concrete, etc. All areas such as these should be sealed with quality sealants and appropriate bond breakers.



Fig.1: Stucco to brick transition needs sealing



Fig.2: Stucco to stone needs to be sealed



4. EIFS/Stucco Information, Care and Maintenance

4.1 TYPES OF STUCCO

A. Exterior Insulation and Finish Systems

Sometimes referred to as synthetic stucco, the materials used to form EIFS vary from manufacturer to manufacturer. EIFS is broken down into two classes, Class PB (polymer based) and Class PM (polymer modified). Class PB is the most commonly used of the two, especially on residential. Figure 1 shows the typical makeup of an EIFS system, although this can vary. The EIFS can be adhered directly to the substrate or mechanically fastened.

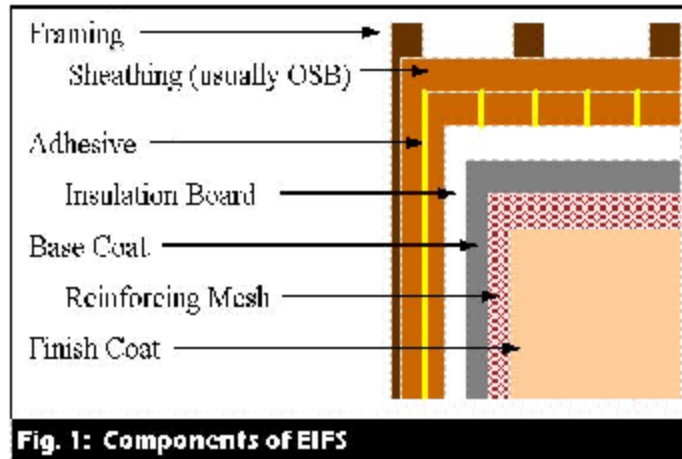

Fig. 1: Components of EIFS

An adhered EIFS is typically considered a "barrier" type cladding system. These systems do not have any built-in drainage capabilities for incidental moisture. Rather, the design intent was that **no** moisture should **ever** get behind the stucco. If water does leak behind the stucco, it can become trapped. The only way out many times is through evaporation—a slow process for an enclosed wall cavity with EPS foam. In a wet climate, it may never have a chance to dry out between rains as long as the leaks continue. Mold, mildew, wallboard damage, rotten sheathing and studs, carpenter ants, and termites can all result—depending upon how long it has been leaking. When these systems utilize oriented strand board (OSB) as the substrate for the stucco, which is common in the residential market, the potential for more serious water damage increases. EIFS that are **mechanically fastened** can have some 'drainage' capability if a properly installed moisture barrier system is present and adequately tied into critical details such as windows, doors, flashings, penetrations, etc. (this is difficult to verify after EIFS installation is complete). However structures with **improperly** installed barrier systems tend to experience the same damages of a structure without any barrier system. Some EIFS have been found to leak from construction onward due to improper installation stucco, flashings and sealants and/or leaky windows and doors. Not all EIFS buildings leak, but they do all require that critical details be properly maintained for continued protection from water intrusion. Even small amounts of leakage over time can cause significant damage to the structure, many times hidden until the damage is severe. Each manufacturer publishes details to guide the stucco applicator, sealant contractor, builder and architect. These details may vary slightly from manufacturer to manufacturer. EIMA, the EIFS Industry Manufacturers Association, publishes a detail guide for the entire EIFS industry.

B. Traditional Hard Coat Systems:

Although these systems have been in use for many decades, in recent years it has become popular to place these systems over wood sheathing and studs. The systems makeup is generally studs, sheathing, felt paper or other moisture barrier, reinforcing lath, scratch, brown and finish coat. The scratch, brown and finish coat are usually cementitious (many use acrylic finishes), mixed in the field, and applied to a thickness of about one inch.

Hardcoat systems are also susceptible to moisture damage if not properly applied, caulked and flashed. In this respect, it is no different than EIFS. Again systems with OSB (oriented strand board) sheathing tend to experience more severe damage when leakage occurs. One disadvantage of traditional hard coat stucco is that it is more susceptible to cracking than synthetic stucco due to expansion and contraction. For this reason, ASTM calls for expansion joints every 144 square feet, as well as between floor lines and at the corners of windows.

C. Water Management or Drainable EIF Systems:

Water management systems typically use a drainage plane behind the stucco coupled with perforated starter strips at the bottom of the walls and under windows to allow any incidental moisture to weep to the outside of the wall. Once the moisture drainage system is properly installed the installation of the EIFS is less critical. Problems can still occur however, if the drainage system is not properly installed (difficult to verify after completion of EIFS application).

4.2 IS EIFS/STUCCO A GOOD CLADDING SYSTEM? Yes, as long as any construction defects, if any, are properly repaired and the system is well maintained, it should provide good long-term performance. There is no such thing as a permanently maintenance free cladding system. Leak problems occur in all types of cladding systems, including brick and vinyl siding. The only difference is that with stucco, the maintenance is more critical. The sealant joints are your first line of defense against water intrusion, and sometimes it's the only line of defense. Water intrusion must be prevented at all costs due to its destructive nature.

4.3 CARE AND MAINTENANCE: The beautiful architectural designs made possible by synthetic stucco systems make these homes very desirable and marketable. It is critical, however, to carefully maintain these systems to prevent water intrusion and deterioration. With the proper care and maintenance, your stucco system should give you many years of beauty and function. It is very important that the five following steps be followed to protect your investment.

(1) Semi-annually (at least annually) inspect all sealant around windows, doors, penetrations through the stucco, stucco transitions (such as stucco to brick, stucco to stone), and stucco terminations (at roof, at grade, at patios or walkways). Arrange for prompt repair of any areas of caulk that is split, cracking, crazing or is losing adhesion. Also, promptly repair any cracks in the stucco.

(2) Any leaks, cracks, areas of discoloration, mold or mildew should be promptly investigated by a certified EIFS inspector. Repairs should be proper and prompt.

(3) Anytime you make a penetration through the stucco such as to mount a satellite dish, add shutters, new wiring, cables, plumbing, security systems, etc., the perimeters must be sealed with a quality sealant approved for EIFS.

(4) Modifications, additions or renovations (including roof replacement) to the structure of any kind should be inspected by a qualified EIFS inspector to ensure waterproofing of critical details is properly performed.

(5) Periodic cleaning of the EIFS/Stucco is necessary to maintain its appearance and prevent permanent staining.

Pressure cleaning equipment must be calibrated to the stucco manufacturer's recommended pressure level (low) to prevent damage to your EIFS/Stucco. Select a firm with experience in cleaning these EIFS systems.